

BX5^{D3}
5" POWERED STUDIO REFERENCE MONITOR

CLARITY
PRECISION
CONFIDENCE



File Name: bx5 d2 manual.pdf

Size: 3616 KB

Type: PDF, ePub, eBook

Category: Book

Uploaded: 21 May 2019, 20:42 PM

Rating: 4.6/5 from 692 votes.

Status: AVAILABLE

Last checked: 14 Minutes ago!

In order to read or download bx5 d2 manual ebook, you need to create a FREE account.

[**Download Now!**](#)

eBook includes PDF, ePub and Kindle version

[Register a free 1 month Trial Account.](#)

[Download as many books as you like \(Personal use\)](#)

[Cancel the membership at any time if not satisfied.](#)

[Join Over 80000 Happy Readers](#)

Book Descriptions:

We have made it easy for you to find a PDF Ebooks without any digging. And by having access to our ebooks online or by storing it on your computer, you have convenient answers with bx5 d2 manual . To get started finding bx5 d2 manual , you are right to find our website which has a comprehensive collection of manuals listed.

Our library is the biggest of these that have literally hundreds of thousands of different products represented.



Book Descriptions:

bx5 d2 manual



Please upgrade your browser to improve your experience. With the BX5 D2, you'll enjoy the utmost accuracy in an engaging listening experience. Accurate monitors let you hear exactly what's happening in your mixes—and give you the assurance that your music will translate well to other listening environments. The MAudio BX5 D2 monitors leverage a decade of monitor engineering expertise to deliver exceptional transparency and sonic definition—allowing you to enjoy marathon mixing sessions with minimal listening fatigue. The BX D2 series makes that same design philosophy and technology available to anyone with a passion for great sound. BX5 D2 helps you understand what's in your mix so you can make better decisions about how it will translate across a wide variety of systems—from MP3 earbuds to car stereos to audiophile rigs. The highfrequency driver is fully isolated from the rest of the enclosure to ensure minimum distortion, providing ultrasmooth frequency response up to 22 kHz. It also features a builtin waveguide, which offers an expansive sound stage and exceptional imaging. Kevlar's high mechanical and thermal resilience makes it ideal for use in speaker cones. Our engineers also created a curved conical design that improves room dispersion. Highdamping reliable rubber surrounds provide percussive musical bass, and insure that the cone reaches its optimal excursion for accurate reproduction. And our hightemperature voice coils reduce power compression, guaranteeing that your monitors will deliver full performance hour after hour. The custom rear port is designed to minimize air turbulence and resulting distortion while adding additional low frequency extension. BX5 D2 features a pinhole power LED that makes finding the sweet spot easy. You'll know you're in the right listening position when the BX5 D2 power LEDs appear to be brightest. Ask your question here. Provide a clear and comprehensive description of the issue and your question.http://sruby.srubystal.pl/user_upload/dell-printer-926-manual.xml

- **m-audio bx5 d2 manual, m audio bx5 d2 manual pdf, bx5 d2 manual, bx5 d2 manual pdf, bx5 d2 manual download, bx5 d2 manual free, bx5 d2 manual review, m-audio bx5 d2 manual.**

BX5^{D3}
5" POWERED STUDIO REFERENCE MONITOR



**CLARITY
PRECISION
CONFIDENCE**

The more detail you provide for your issue and question, the easier it will be for other MAudio BX5 D2 owners to properly answer your question. Ask a question About the MAudio BX5 D2 This manual comes under the category Speakers and has been rated by 1 people with an average of a 7.2. This manual is available in the following languages English, German, French, Spanish, Italian. Do you have a question about the MAudio BX5 D2 or do you need help. Ask your question here MAudio BX5 D2 specifications Brand The distance between the two devices that exchange data can in most cases be no more than ten metres. When the volume exceeds 120 decibels, direct damage can even occur. The chance of hearing damage depends on the listening frequency and duration. This makes it possible to create a 5.1 effect with only 1 speaker. ManualSearcher.com ensures that you will find the manual you are looking for in no time. Our database contains more than 1 million PDF manuals from more than 10,000 brands. Every day we add the latest manuals so that you will always find the product you are looking for. Its very simple just type the brand name and the type of product in the search bar and you can instantly view the manual of your choice online for free. ManualSearcher.com If you continue to use this site we will assume that you are happy with it. Read more Ok. Por favor, intentalo de nuevo mas tarde. Intentalo de nuevo. Para salir de este carrusel, utiliza la tecla de acceso directo del encabezado para desplazarte al encabezado siguiente o anterior. Para salir de este carrusel, utiliza la tecla de acceso directo del encabezado para desplazarte al encabezado siguiente o anterior. Para salir de este carrusel, utiliza la tecla de acceso directo del encabezado para desplazarte al encabezado siguiente o anterior. Full content visible, double tap to read brief content. Intenta mas tarde hacer tu busqueda de nuevo. <http://www.seikan.cz/userfiles/dell-printer-manual-924.xml>



The BX5 D2 monitors ensure you hear exactly what's happening in your mixes, so you can be confident that your music will sound its best in any listening environment. Premium components, advanced cabinet design, and efficient bi-amplification come together to provide superior audio reproduction. This biamped design ensures that each driver is sent only the frequencies that it can

reproduce most efficiently, producing clean power and plenty of headroom. The woven Kevlar lowfrequency driver offers rich and articulate bass. The natural silk dome highfrequency driver uses a builtin waveguide to add clarity. Comprehensive Cabinetry These impressive cabinets take up very little valuable space in your studio, yet are loaded with professional features, from radialedge corners that reduce edge diffraction to magnetic shielding for safe use near video monitors. The bass porting is optimized to extend the lowend response, and there is an isolated chamber for the highfrequency driver. The power switch, voltage selector, detachable power cord socket, and volume control are easily accessed via the rear panel. Acoustic isolation pads are included. Cualquier computadora devuelta que se encuentre danada por mal uso del cliente, le falten piezas o este en condicion inaceptable debido a la manipulacion del cliente tendra como resultado un cargo al cliente por reposicion con base en la condicion del producto. Amazon.com no aceptara devoluciones de cualquier computadora de escritorio o computadora personal despues de 30 dias de que hayas recibido el envio. Productos nuevos, usados y restaurados comprados de vendedores del Marketplace estan sujetos a la politica de devoluciones del vendedor individual. Amazon calcula la calificacion de estrellas de un producto utilizando un modelo de aprendizaje mecanico en lugar de un promedio de datos sin procesar.

El modelo de aprendizaje mecanizado toma en cuenta factores que incluyen la edad de una resena, los votos de ayuda de los clientes y si las opiniones pertenecen a compras verificadas. Vuelva a intentarlo en otro momento. Compared to similar sized consumer speakers, they are a bit understated and without bass bloat or exaggerated highs. The even keeled tonal signature is pleasing and easy to listen to for hours. It also lacks a midrange bump, and sounds a bit recessed or laidback compared to average earbuds or home speakers. In fact the BX5 sounds similar to my Sennheiser 580HD headphones, but with less lower bass. Unlike typical passive stereo speakers, the BX5 is powered with separate amplifiers for the tweeter and woofer, i.e., biamped. This design allows for accurate reproduction as amplifiers are optimized for each driver. The downside to this design is each speaker needs both input and power cables, so not convenient for living room use but not a problem for nearfield computer based editing. At first the BX5 struck me as underpowered for a 70 watt rating, at least with a signal directly from my Mac Pro. However, once jacked into the hotter signal from my MOTU Ultralite the true power of the BX5 was revealed. It was loud and could be painfully so if cranked. These are directional speakers and render placement of instruments in a stereo soundfield accurately as long as you sit in the sweet spot a couple feet out your head should form a triangle with the two speakers. That diffuse room filling tone of home theatre speakers is MIA. In fact, unlike most speakers, there is little rearwards projection. Perfect for not bothering family or neighbors but bad for parties. So dont buy these for standard stereo or home theatre use. I mainly mix classical and acoustic guitar solo and ensemble recordings, live and multitrack, so the bass range is perfect for me. The bass extends down to a clear 60Hz, so plenty ump for dropD and dropC tuning.

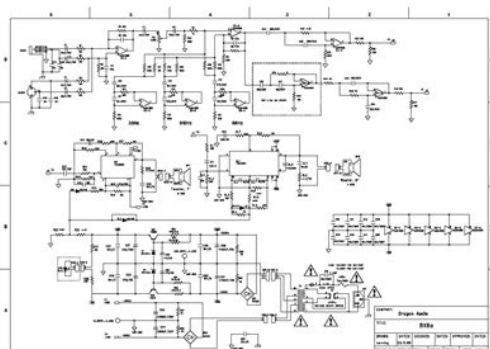

<http://www.bosport.be/newsletter/3m-9050-overhead-projector-manual>

If you mix bass guitar and kick drum you'll want larger speakers BX8 or a sub but these are great for guitar. I'm used to mixing with neutral speakers and headphones but it would be nice if you could adjust bass, mid and highs for different room responses and taste. Oddly, the PDF instructions show EQ switches for the prior version of this model but they are missing from my speakers. I assume they were omitted as a cost cutting measure. RFI RESISTANCE I'm an inner city dweller and live in a high RFI area. Cheap audio gear acts like a radio receiver and injects a local classic rock station into my mixes. So one of the major selling points for me was MAudio's claim of RFI shielding. Luckily that was no mere marketing jive. They really are well shielded against RFI. Not a single wayward drum loop or DJ in my tracks, not even when cranked. I can't make that claim for prior speakers I've owned. HEAT These speakers run on the warm side the upper back is fairly warm just idling and can get hot to the touch after a long session. Not egg frying hot but a wee bit uncomfortable to the fingertips. It has a sensor to shut it down in case of excessive heat. However I have not seen it shutdown even after all day editing sessions. I live in the balmy tropics so cold weather dwellers may not see as much heat build up. Not a deal breaker but it's wise to turn them off when not in use I use a power strip so I don't have to flip two separate switches. CONSTRUCTION These are handsome units in a blend in your gear sort of way the black finish matches perfectly with my black trimmed Cinema Display and MOTU Ultralite. Construction appears very good with dense particle board MDF cabs, metal back plate heat sink benefit and matching plastic front molding around the drivers. The cabs are covered with a satin black vinyl. These monitors are petite and smaller than most speakers with the same sized bass driver. The bass drivers are Kevlar with rubber surrounds tougher than foam!

<http://curabona.com/images/braun-3106-manual.pdf>

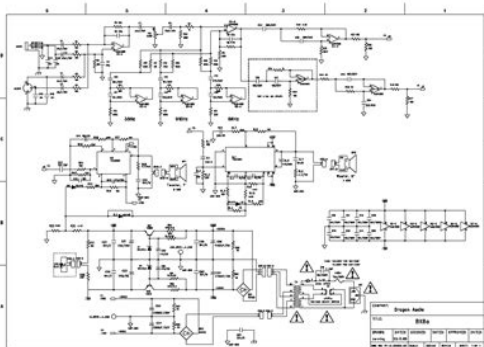

and the tweeters sport silk domes. No protective grill or covers as usual for mixing monitors. So the naked drivers can be easily damaged by a careless finger or chopstick. If you're a novice recordist or a civilian buying these for general computer use, be forewarned there are no stereo mini jacks, RCA or USB. So you will need to pay extra for a set of special cables and adapters. If you're an experienced recordist, you should have plenty of these cables laying around but, otherwise, be prepared to reach for your wallet. One of the things I like about the BX5 is both the TRS and XLR connections are active at the same time, allowing the monitors to receive signals from two different sources without messing with cables or switches. LAST BLURB Yes, the small Focal speakers I listened to were better sounding and louder than the BX5 but cost a couple toes and a month of lunches. However, a perfect monitor for a home studio isn't only about a good neutral sound, but also about compactness, appearance and value. And the BX5 nails all of these while still sounding pretty damn fine. They had the right RCA connectors to integrate together and I ended up using RCA to

XLR cables from the sub. The input is RCA from an MAudio Delta 1010LT card in my PC. The technical review from P.K. is spot on so I wont add there. I felt the MAudio SBX10 sub was too big for my office room so the AS8 turned out to be the right choice to integrate with these BX5 monitors. I like the neutral sound stage this setup produces and am working on tweaking the crossover and sub volume to match the monitor volume i require. I listen to a lot of cello, guitar, orchestra, and choral so accurate and neutral is what I like. Not to say these monitors cant generate volume on RATM, Soundgarden, Who, Zeppelin, and Rory Gallagher 73 Irish Tour. Wow. The silk dome tweeters were important to me since i prefer them on all my stereo gear and the separate amplifiers are a plus.

<http://cydistribution.com/images/braun-330-shaver-manual.pdf>



It takes a little more effort to dial them in but its once and done. These replaced my Klipsch Pro Media 2.1 that crapped out after 8 years. This setup is definitely the next level but at 4x the cost of the Klipsch it should be. I hope to do some recording and playback soon. Cheers It was easy to adjust my EQ on my laptop to produce awesome listening music, just beautiful, clear, nicely separated sound. I wouldnt use these for high volume stuff, the sound is almost delicate, and very precise in its separation. The classical musicians in our guild loved the sound, that should tell you something. Stunning, really. They are, in fact, exactly what they are advertised to be top notch small room project studio monitors. I readjusted my EQ for the needed flat response for sound engineering and I was extremely pleased with the results. The sound you can get out of these is so varied that we needed to give our hearing time to adjust, as the flat studio mixing EQ sounded horrible at first, as it should. I have been in and out of studios for 30 years and I can say, used appropriately, these are excellent nearfield mixing monitors. Take time to review the set up data from MAudio, its good stuff, and dont ask these little beauties to be everything, just let them be what they were made to be... and enjoy! We ended up remixing half a dozen acoustical songs off a recent project with these via Cubase 7 and the general consensus is that the mixes improved by 30%. Ive had them about 3 weeks so far, no issues. But Im keeping the box just in case. I use them for music production. I have them connected to a Focusrite Scarlett 2i2 with two TRS cables. Although i wish i got the 2i4 since i cant hook up a sub now. Also i guess the specifications didnt go into detail about the isolation pads but i got two very thin pieces of cardboard. I thought theyd be the foamy wedge type ones but im new to this so what i received is probably correct.

If you are starting out in music production i think these are the perfect speakers to get. If you are just casually listening to music or games then these would suit your needs too i would think! He is very happy with this item and recommends them thoroughly. They produce a really good range of sound and also have a nice deep bassy sound too. The price suggests they are of the lower end DJ

monitors but they actually are more than respectable for any budding or home DJ who doesn't need to pay the price for professional standard monitors. They came in the original boxes, within more boxes and surrounded with bubbles and polystyrene so there was no issue with delivery or transport. Would definitely recommend for the price and the sound quality I have heard from them. Gracias por su comentario. Lo sentimos, no hemos podido registrar tu voto. Vuelva a intentarlo Great entry level monitors. I was very impressed by the quality and loudness in the edit suites so decided to buy a pair. These are much cheaper than most of the other monitors out there and whilst they probably aren't as good and accurate as some of the much more expensive ones, they are very decent. I use these in a home setup plugged into a mixer to do video editing and a lot of general listening, music and a bit of gaming. These are very good for the price and can go pretty loud without distorting, they look really cool and the choice of XLR or Jack input is nice. I would recommend using these with some isolation pads and having them well positioned to get the best experience, when there is no input there is virtually no hiss or noise whatsoever, very clear mids and highs with a decent kick of bass. If you use a lot of low end then maybe invest in the larger BX6 or BX8 monitors or even pair these with an SBX10 for some serious low end power. Gracias por su comentario. Vuelva a intentarlo Its been a revelation to revisit some of my old mixes made on headphones and HiFi speakers. Mortifying too!

<https://diagonal.org.ar/wp-content/plugins/formcraft/file-upload/server/content/files/1626ebc508018f---bosch-maxx-900-manual.pdf>

These monitors have a generally flat response with good transients and detail and a slight but only slight uppermid boost. They are excellent for vocals, stringed instruments and drums. Kicks have plenty of punch and treble is rendered smoothly, but with no trace of dullness. They play loud enough for nearfield monitors, but don't lose presence when you turn them down. The one reservation is in the bass. The lowend response is good and pretty flat, but it tails off very suddenly this is typical of small ported speakers. With little output below around 60 Hz and a fast fallaway its almost impossible to mix material with significant deep bass accurately. For that you're going to need a sub, good headphones, or a pair of much bigger and far more expensive monitors. However, for the money they are a fantastic bargain and for a lot of music and project work they are all you're likely to need. Gracias por su comentario. Vuelva a intentarlo I got them for my computer as my current 5.1 sat set is perfectly fine for games, but are lacking when playing music. I have them hooked up using a good external DAC and have also added a good cd player to them. The sound quality of these speakers is excellent considering the price. From lossless tracks, cd player and even decent mp3 if there is such a thing sound very good. Way better than I expected so I have certainly kept them. The clarity and separation is excellent for the price and I am very happy with them. These are the mid sized units so can only reproduce low frequency to a point, but you can still clearly hear the bass lines without it overwhelming the rest of the tune. If my computer room was bigger I would have opted for the next model up and purchased stands for them, but since they are sitting on my desk, I opted for the foam isolation pads Auralex MoPads which are expensive but good. I am very happy with these speakers as I didn't expect them to shake the doors in my house with epic bass. Gracias por su comentario.

Vuelva a intentarlo Well, unfortunately, or fortunately, these speakers still provide a ton of bass. So if you're considering not buying them because they might not have enough bass, don't let that stop you. The audio balance is great and the bass is certainly strong enough. They also make great bookshelf speakers. Gracias por su comentario. Vuelva a intentarlo Well all can say to that is rubbish. They are not really full studio quality for that you need their big brothers the BX8as. For a small recording set up they have enough range to satisfy most ears. Lots of low, mid and high punch. Would I buy them again YES. Gracias por su comentario. Vuelva a intentarlo They are superb and the price is a snip for this quality. I play FLAC files on external WD hard drives, hooked up to my PC,

through a Steinberg UR22 linked via Rapid Cables stereo TRS jack to jack balanced leads plugged into a pair of these cracking speakers. The output is great, even on full power these speakers hardly distort at all. Half volume is enough to fill my garden with a rich, full sound, Big garden, no neighbours Great on a summer evening with a few cans. Gracias por su comentario. Vuelva a intentarlo Whereas the bass is very punchy and fairly clear cut, there is very little or no mass distortion when played at a high volume for long periods of time. Generally the speakers do not get that hot but definitely on the warm side after being left on for 24 hours. What I would suggest you purchase along side the monitors to make them as an enjoyable experience as possible simply because you are contemplating buying monitors and not speakers is Adam Hall 3 Star Series 3m 2x RCA Male to 2x 6.3mm Jack Mono Audio Cable This is essentially one cable with four plugs Behringer 302USB Xenyx 5 Input Mixer Cheap external sound card, this does the trick. Gracias por su comentario. Vuelva a intentarlo These are the best speakers I have ever owned.

I bought them as monitors for a mixing desk that didnt work so went back and now use them with my phone, ipad etc. Have connected my guitar through an amp simulator app and very pleased with the results Gracias por su comentario. Vuelva a intentarlo They sound great for the price. Ive done some mixing with them and I listen to music almost everyday with them and they capture everything. I do recommend getting a subwoofer to give you that bass but these speakers do surprisingly well across the spectrum. Ace. Gracias por su comentario. Vuelva a intentarlo Its like someones removed the curtains from my old ones and the sound is pouring out as it should. Even lossy compressed music sounds better. Im hearing details in tracks Ive listened to a thousand times before and not noticed. Gracias por su comentario. Vuelva a intentarlo These actually sound better than bigger speakers in a room this size. Very good bass response. I also have the BX8s, but in my opinion they only sound significantly better in a room thats bigger than 7 x 7 metres, then especially when combined with the B10S subwoofer these sound really great. MAudio are great value for money, I recommended this BX series if you are new to producing or DJing and want something that sounds great without breaking the bank. Gracias por su comentario. Vuelva a intentarlo The speakers are great, and while slightly bass light they still deliver a nice enough lower frequency presence. I use them for gaming, casual music listening and music production and can say that they perform well in all situations one note is that if you want these for a music production set up I would recommend referencing on a good pair of headphones for those low ends. They do not come with cables, so i picked up some XLRs which work really well with them.

Regrettably the price of the BX8s are now only 200 and had i known i would of purchased those instead for the lower end frequencies but all in all the BX5s are really nice and i would highly recommend them. Gracias por su comentario. Vuelva a intentarlo Gracias por su comentario. Vuelva a intentarlo However I get interference. Which Ive read can be causes by a power source or interference from other electronics Gracias por su comentario. Vuelva a intentarlo. Giv en klar og omfattende beskrivelse af problemet og dit sporgsmål. Jo flere oplysninger du giver om dit problem og dit sporgsmål, jo lettere er det for andre MAudio BX5 D2 ejere at svare korrekt pa dit sporgsmål. Stil et sporgsmål Om MAudio BX5 D2 Denne vejledning horer under kategorien Højtalere og er blevet bedomt af 1 personer med et gennemsnit pa en 7.2. Denne manual er tilgængelig pa følgende sprog Engelsk, Tysk, Fransk, Spansk, Italiensk. Har du et sporgsmål om MAudio BX5 D2 eller har du brug for hjælp Stil dit sporgsmål her MAudio BX5 D2 specifikationer Mrke Hvis støjniveauet er over 120 decibel, kan der endda opsta direkte skader. Risikoen for høreskader afhnger af lyttefrekvensen og varigheden. Dette gor det muligt at skabe en 5.1 effekt med kun 1 højtaler. PDFmanualer.dk sikrer, at du hurtigt kan finde den manual, du leder efter. Vores database indeholder mere end 1 million PDFmanualer fra mere end 10.000 mrker. Hver dag tilfojer vi de nyeste manualer, sa du altid kan finde det produkt, du leder efter. Det er meget simpelt du skal bare indtaste mrke og produkttype i søgefeltet og du kan straks se den manual du onsker, online og gratis. PDFmanualer.dk Hvis du fortstter med at bruge dette site vil vi antage at du er indforstået med det. Ls mere Ok.

Please try again. In order to navigate out of this carousel please use your heading shortcut key to navigate to the next or previous heading. Please try your search again later. You can edit your question or post anyway.

Amazon calculates a products star ratings based on a machine learned model instead of a raw data average. The model takes into account factors including the age of a rating, whether the ratings are from verified purchasers and factors that establish reviewer trustworthiness. Please try again later.

Shrimanth patil 5.0 out of 5 stars Amazing clarity and sound. must buy Best service by Amazon. Fully satisfied with product. Only one issue. back side of monitor heated after short time. Is it by default or there is some problem that I dont know Best studio monitor. He is very happy with this item and recommends them thoroughly. Would definitely recommend for the price and the sound quality I have heard from them. Sorry, we failed to record your vote. Please try again Great entry level monitors. I was very impressed by the quality and loudness in the edit suites so decided to buy a pair. If you use a lot of low end then maybe invest in the larger BX6 or BX8 monitors or even pair these with an SBX10 for some serious low end power. Sorry, we failed to record your vote. Please try again Its been a revelation to revisit some of my old mixes made on headphones and HiFi speakers. However, for the money they are a fantastic bargain and for a lot of music and project work they are all youre likely to need. Sorry, we failed to record your vote. Please try again I got them for my computer as my current 5.1 sat set is perfectly fine for games, but are lacking when playing music. I am very happy with these speakers as I didnt expect them to shake the doors in my house with epic bass. Sorry, we failed to record your vote. Please try again Well, unfortunately, or fortunately, these speakers still provide a ton of bass. They also make great bookshelf speakers. Sorry, we failed to record your vote. Please try again Well all can say to that is rubbish. Would I buy them again YES. Sorry, we failed to record your vote. Please try again They are superb and the price is a snip for this quality.

Half volume is enough to fill my garden with a rich, full sound, Big garden, no neighbours Great on a summer evening with a few cans. Sorry, we failed to record your vote. Please try again Whereas the bass is very punchy and fairly clear cut, there is very little or no mass distortion when played at a high volume for long periods of time. What I would suggest you purchase along side the monitors to make them as an enjoyable experience as possible simply because you are contemplating buying monitors and not speakers is Adam Hall 3 Star Series 3m 2x RCA Male to 2x 6.3mm Jack Mono Audio Cable This is essentially one cable with four plugs Behringer 302 USB Xenyx 5 Input Mixer Cheap external sound card, this does the trick. Sorry, we failed to record your vote. Please try again These are the best speakers I have ever owned. Have connected my guitar through an amp simulator app and very pleased with the results. Sorry, we failed to record your vote. Please try again They sound great for the price. I do recommend getting a subwoofer to give you that bass but these speakers do surprisingly well across the spectrum. Ace. Sorry, we failed to record your vote. Please try again Its like someones removed the curtains from my old ones and the sound is pouring out as it should. Im hearing details in tracks Ive listened to a thousand times before and not noticed. Sorry, we failed to record your vote. Please try again These actually sound better than bigger speakers in a room this size. MAudio are great value for money, I recommended this BX series if you are new to producing or DJing and want something that sounds great without breaking the bank. Sorry, we failed to record your vote. Please try again The speakers are great, and while slightly bass light they still deliver a nice enough lower frequency presence.

Regrettably the price of the BX8s are now only 200 and had i known i would of purchased those instead for the lower end frequencies but all in all the BX5s are really nice and i would highly recommend them. Sorry, we failed to record your vote. Please try again Sorry, we failed to record your vote. Please try again However I get interference. Which Ive read can be caused by a power source or interference from other electronics. Sorry, we failed to record your vote. Please try again.

<http://www.diamondsinthemaking.com/content/3m-9050-overhead-projector-manual>